

SCR Series



SPECIFICATIONS

Input Voltage 24 VAC, 20 to 36 VDC Class 2
 Analog Output 4-20 mA (clipped & capped)/
 0-5 VDC/0-10 VDC (selectable)
 Sensor Current Draw 20-36 VDC 50 mA avg.,
 150 mA max.
 24 VAC 120 mA avg., 170 mA max.
 Operating Temperature Range
 No Humidity option: 0° to 50°C (32° to 122°F)
 With Humidity Option: 10° to 35°C (50° to 95°F)
 Operating Humidity Range 0-95%
 (noncondensing)
 Housing Material High impact ABS plastic

CO₂ Transmitter

Sensor Type Non-dispersive infrared (NDIR),
 diffusion sampling
 Output Range 0-2000 ppm
 Accuracy ±1.5% of measurement range
 ±2% of measured value*
 Repeatability ±20 ppm ±1% of measured value

Schneider Electric's SCR series of wall mounted Living Space sensors measure the levels of CO₂, RH (if equipped) and temperature of air inside a room. The CO₂ sensor employs the Automatic Baseline Calibration (ABC) feature, which enables the sensor to operate within accuracy specifications for the calibration interval of 5 years. RH equipped models of the SCR feature a replaceable humidity element. HS2NX and HS2XX replaceable humidity elements are available through Schneider Electric. To maintain accurate functionality, keep all vents free of dust, debris, etc.

Response Time <60 seconds for 90%
 step change

RH Transmitter

HS Sensor Digitally profiled thin-film capacitive
 (32-bit mathematics); U.S. Patent 5,844,138
 Accuracy ±2% from 10 to 80% RH @ 25°C
 Hysteresis 1.5% typical
 Linearity Included in Accuracy spec.
 Stability ±1% @ 20°C (68°F) annually,
 for two years
 Output Range 0 to 100% RH
 Temperature Coefficient ±0.1% RH/°C above or
 below 25°C (typical)

Temperature

Sensor Type Thermistor (see thermistor table
 for temperature curves)
 Accuracy ±0.5°C (±1°F) typical

Relay Contacts

1 Form C 1 A@30 VDC, resistive; 30 W max.

Specified accuracy with 24 VDC supplied power with rising humidity. Thermistors are not compensated for internal heating of product.

EMC Conformance

. EN 61000-6-3: 2007 Class B;
 EN 61326-1: 2006 Class B;
 EN 61000-6-2: 2005

Environmental Rating

. IP20; NEMA 1

*Accuracy is specified at NTP (20°C at 101.3 kPa).

DIMENSIONS

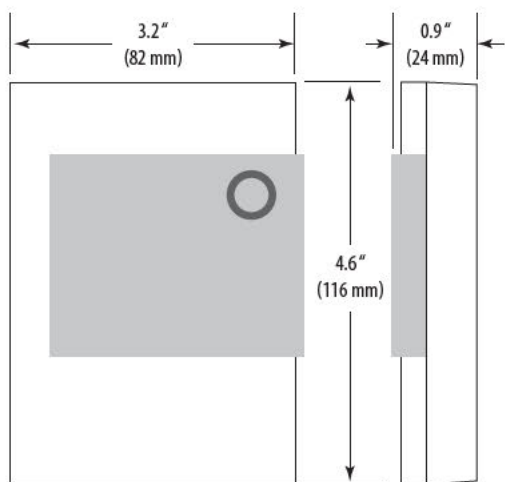

INSTALLATION

1. Remove the outer cover by using a screwdriver to depress the two tabs on the top of the device. This unclips the top half of the housing. Repeat on the tabs on the bottom of the device to remove the cover.
2. Remove the backplate by lifting up on the bottom of the board and pivoting it upward. Remove the board assembly from pivot pins.
3. Position the backplate vertically on the wall, 4.5 feet (1.5 m) above the floor. Locate away from windows, vents, and other sources of draft. If possible, do not mount on an external wall, as this might cause inaccurate temperature readings.
4. Mount the backplate onto the wall using screws (not included).
5. Wire the device and configure output and DIP switches. See Wiring and Configuration section.
6. Set ABC jumper to On or Low position. See ABC Calibration section.
7. Re-affix board assembly onto backplate. Snap outer cover in place.

Insert screwdriver into tabs to release cover.

Observe handling precautions for static sensitive devices to avoid damage to the circuitry which would not be covered under the factory warranty.

13 screwholes available; use a minimum of two for secure mounting.

If these two holes are selected, tighten the screws so that the screw heads are fully recessed in the housing.



WIRING AND CONFIGURATION

1. Connect wires as shown.
2. Refer to specifications for power requirements and relay rating.
3. Select mA or Volt output using selector switch.
4. If Volt output is selected, select 5 V (0-5 VDC) or 10V (0-10 VDC) using switch 1 on the 4 throw dipswitch.
5. Select a relay setpoint of 800, 1000 or 1200 ppm of CO₂ using switch 2 and 3 on the 4 throw dipswitch. The factory default is the "Relay Disabled" position.
6. Select deadband of 50 ppm or 100 ppm using switch 4 on the 4 throw dipswitch. This setting allows for additional flexibility when using the relay setpoint. The actual relay trip point is the setpoint ppm ± the deadband ppm. Example: If the relay setpoint is set for 1000 ppm and the deadband is set for 50 ppm, with dropping CO₂ levels the relay will trip at 950 ppm (1000 ppm - 50 ppm), with rising CO₂ levels the relay will trip at 1050 ppm (1000 ppm + 50 ppm).

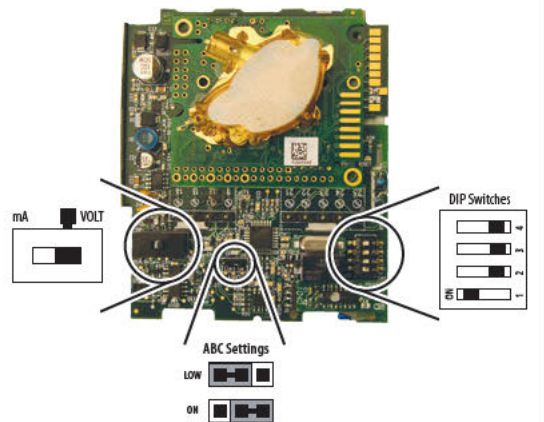
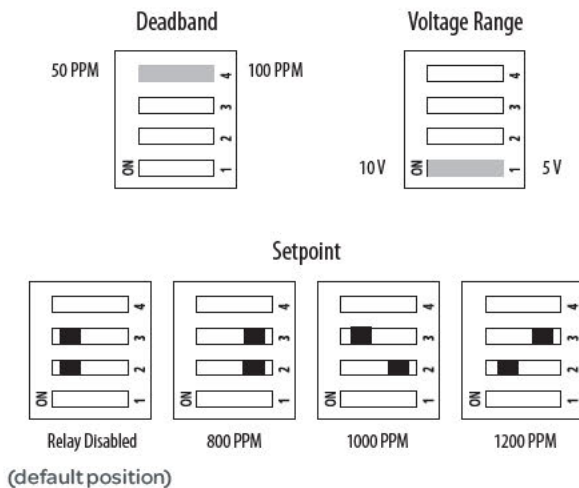
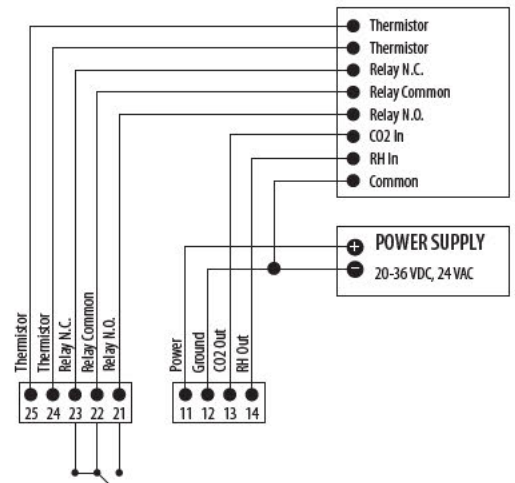

ABC CALIBRATION ALGORITHM:

ABC (Automatic Baseline Calibration) is a patented self-calibration feature that automatically adjusts the CO₂ sensor to compensate for drift. The sensor records the lowest reading within every 24-hour interval and compares these values over a running 7-day or 28-day period. If a statistically significant amount of drift is detected, the ABC applies an automatic correction factor. This enables the sensor to operate within specifications for the 5-year calibration interval.

ABC Settings

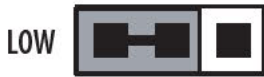

ON POSITION. Recommended Setting. Use the ON setting for applications where the building is unoccupied within a 24-hour timeframe.

LOW POSITION. Use the LOW setting for buildings occupied 24 hours a day.

NOTE: After changing the ABC settings, power cycle the unit for changes to take effect.

INDICATOR LED:

SCR sensors equipped with the LED option have an LED on the faceplate that provides status indication.

SCR sensors not equipped with the LED option do not have an LED indicator on the faceplate (Blank versions). They do, however, have internal LEDs that provide status indication similar to the LED versions.

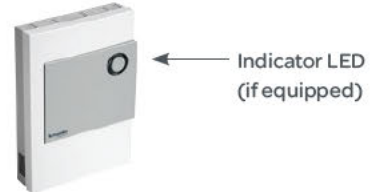

Green	Normal Operation
Yellow	CO ₂ levels have exceeded setpoint (if enabled)
Flashing Yellow	Out of range or diagnostic event detected

HUMIDITY SENSOR REPLACEMENT

SCR models with optional RH have replaceable humidity sensors.

To Replace Humidity Sensor:

1. Disconnect power to the unit.
2. Remove faceplate.
3. Remove HS element by gently pulling from pin connector.
4. Place new HS element onto pin connector. Orient as shown, or unit will not function.
5. Replace faceplate.



OUTPUT SCALING

CO₂ Output scaling: 0-2000 ppm

	CO ₂ ppm	0-5 Volt Output	0-10 Volt Output	mA Output
Outside	300-500	0.75 to 1.25	1.5 to 2.5	6.4 to 8
Over-Ventilated	Under 600	under 1.5	Under 3	Under 8.8

RH Output scaling: 0-100%

AVAILABLE PRODUCTS

Part Number	Wall Mounted CO ₂ Sensor with			
	LED	Temp	2% RH	System
SCR110	x	x		TAC Vista
SCR110-H	x	x	x	TAC Vista
SCR110B		x		TAC Vista
SCR110B-H		x	x	TAC Vista
SCR210	x	x		TAC I/NET
SCR210-H	x	x	x	TAC I/NET
SCR210B		x		TAC I/NET
SCR210B-H		x	x	TAC I/NET
SCR510	x	x		Andover Continuum
SCR510-H	x	x	x	Andover Continuum
SCR510B		x		Andover Continuum
SCR510B-H		x	x	Andover Continuum
SCR610	x	x		Satchwell
SCR610-H	x	x	x	Satchwell
SCR610B		x		Satchwell
SCR610B-H		x	x	Satchwell
SCR810	x	x		TAC I/A Series
SCR810-H	x	x	x	TAC I/A Series
SCR810B		x		TAC I/A Series
SCR810B-H		x	x	TAC I/A Series
VER-HS2NX		Replaceable RH Element, 2%, NIST		
VER-HS2XX		Replaceable RH Element, 2%		

THERMISTOR TABLE

°C	°F	TAC Vista 1.8K	TAC I/NET 10K T2	Andover Continuum 10K T3	Satchwell 10K T3 w/Resistor & Shunt	TAC I/A Series 10K T3 w/Shunt
0	32	5,096	32,773	29,575	7,480	8,018
5	41	4,077	25,456	23,504	7,024	7,493
10	50	3,287	19,931	18,809	6,541	6,941
15	59	2,671	15,725	15,146	6,039	6,372
20	68	2,185	12,497	12,271	5,530	5,800
25	77	1,800	10,000	10,000	5,025	5,238
30	86	1,492	8,055	8,195	4,534	4,696
35	95	1,245	6,528	6,752	4,066	4,184
40	104	1,044	5,323	5,592	3,627	3,707
45	113	881	4,365	4,655	3,222	3,271
50	122	747	3,599	3,893	2,854	2,875